

Instructions: You have a total of 50 minutes to complete this test.

Answer each question completely showing complete details.

For complete credit you must include correct SI units with numerical answers.

Time Start _____ Time finish _____ pledged _____

$$\text{Constants: } k=8.987 \times 10^9 \frac{\text{Nm}^2}{\text{C}^2}; \epsilon_0=8.854 \times 10^{-12} \frac{\text{C}^2}{\text{Nm}^2}; \mu_0=4\pi \times 10^{-7} \frac{\text{Tm}}{\text{A}}$$

[1] Consider the circuit shown above. Write the Kirchoff's laws equations that result from the following:

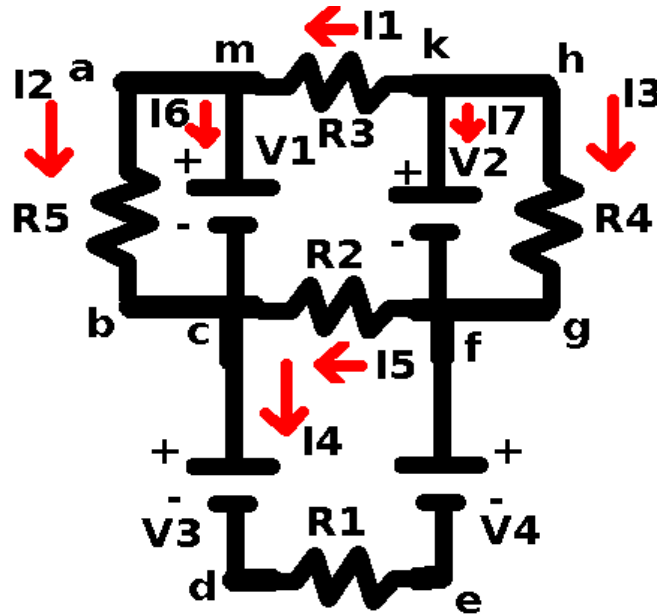

(a) loop (abcma): _____

(b) loop(mcfkm): _____

(c) loop (kfhgk): _____

(d) loop (cdefc): _____

(e) @c: _____

(f)@f: _____

(g) @k: _____

If the components have the following values:

$$R1=1\Omega, R2=2\Omega, R3=3\Omega, R4=4\Omega \text{ and } R5=5\Omega$$

$$V1=10V, V2=20V, V3=30V, V4=40V$$

The following currents result:

$$I1=7.1 \text{ A}, I2=2.0 \text{ A}, I3=5.0, I4=-1.4 \text{ A}, I5=5.7 \text{ A}, I6=-9.1\text{A}, I7=2.1 \text{ A}$$

(h) Calculate the power radiated by resistor R1.

(i) What is the interpretation of the value provided for current I6?

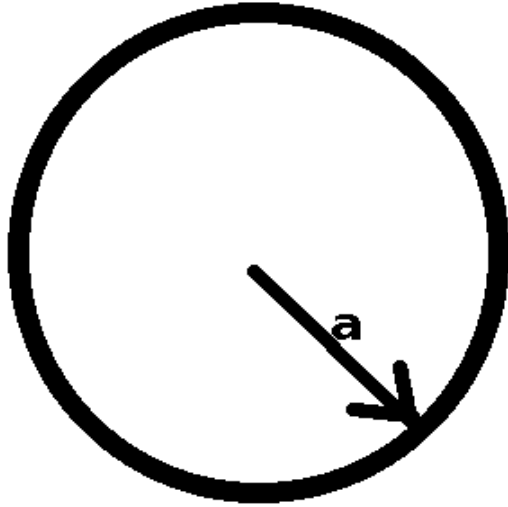

[2] A wire of radius a carries a **uniform** current density given by $\vec{j} = -|\vec{j}|\hat{z}$ which is directed into the page. The wire carries a total current I .

(a) Which direction does the magnetic field circulate around the wire? (circle the correct answer below).

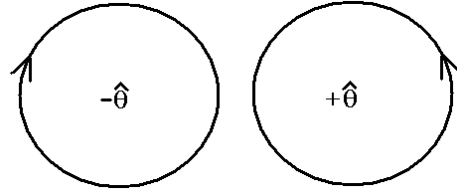

(b) Calculate the magnitude of the current density, $|\vec{j}|$ in terms of I and a .

(c) Showing complete details, including sketches as necessary, calculate the vector magnetic field outside the wire in terms of I , and the radius vector r .

(d) Showing complete details, including sketches as necessary, calculate the vector magnetic field inside the wire in terms of I , a and the radius vector r .

(e) Suppose $I=10$ A and $a=0.1$ m. Find the magnitude of the magnetic field at the surface of the wire with correct SI units.

[3] A particle of mass m and charge q is accelerated through a potential difference V and then injected into a uniform magnetic field.

(a) The kinetic energy the particle has after acceleration is given by (in terms of V and q) is given by:

(b) the velocity of the particle is given by (in terms of V , m and q):

(c) if the velocity is given by $\vec{v}=u\hat{x}$ and the magnetic field is given by $\vec{B}=B\hat{z}$, the direction of the magnetic force on the particle (assuming a positive charge) is given by:

(d) The radius of orbit of the particle is given by:

Provide numerical results for the case that $m=1\times 10^{-6}$ kg, $q=1\ \mu\text{C}$, $V=1\times 10^6$ V and $B=10$ T for a, b, c, and d with correct SI units.

[4]

(a) If R_1 has a resistance of 10Ω and resistor R_2 has a resistance of 100Ω , calculate the resistance of the two resistors when connected in series.

(b) If R_1 has a resistance of 10Ω and resistor R_2 has a resistance of 100Ω , calculate the resistance of the two resistors when connected in parallel.

(c) If C_1 has a capacitance of $5 \mu\text{f}$ and C_2 has a capacitance of $8 \mu\text{f}$, calculate the capacitance of the two capacitors when they are connected in series.

(d) If C_1 has a capacitance of $5 \mu\text{f}$ and C_2 has a capacitance of $8 \mu\text{f}$, calculate the capacitance of the two capacitors when they are connected in parallel.

(e) Calculate the RC time constant when a resistor ($R=4 \times 10^6 \Omega$) is connected in series with a capacitor ($C=4 \mu\text{f}$).

(f) In a series RC circuit, if the capacitor has an initial charge separation Q_0 , how long (in seconds) will it take until the charge is reduced to $Q_0/2$ if the resistor is $R=4 \times 10^6 \Omega$ and the capacitor is $C=4 \mu\text{f}$