

## Oscilloscopes, Signal generators and RF impedance analysis

revised 2018

**Note well: this analysis applies to series circuits only.**

In today's lab, you'll use a frequency generator together with the storage oscilloscope. I recommend only that you make only slight adjustments to the equipment until you learn a bit about how it works. You'll find a step-by-step procedure at the end of this writeup that will help with data measurement and acquisition. A significant part of today's lab is that you have some hands-on experience with oscilloscopes. Make sure that every member of your team gets some hand-on experience.

**Note that I have provided a list of frequencies for you to measure. Note that these frequencies are approximate but you need a total of 19 frequencies (in order as shown). For LP (about 6 Hz), start at the lower frequencies and go up. For HP, start at the higher frequencies and go down. For RLC, start at the lower frequencies and go up. I have taken example frequencies directly from my measurements on the spreadsheets, but again, the exact value is not essential, just be fairly close to my values.**

### About RMS values:

Suppose a sinusoidally varying current is applied across a resistor  
(We're initially assuming the circuit is purely resistive):

$$I = I_m \sin(\omega t)$$

$$V = V_m \sin(\omega t)$$

The instantaneous power radiated is given by:

$$P = IV = I_m V_m \sin^2(\omega t)$$

It is not the instantaneous power which is so interesting: it is the time average power.

This is given by:

$$\langle P \rangle = I_m V_m \langle \sin^2(\omega t) \rangle$$

From last semester, we know the time average of  $\sin^2(\omega t)$  has the value of  $\frac{1}{2}$ . Thus:

$$\langle P \rangle = \frac{1}{2} I_m V_m$$

If we wrote, instead of the peak voltages and currents, these peaks scaled, we can make the form look the same as for DC. Thus, we define:

$$I_{\text{rms}} \equiv \frac{I_m}{\sqrt{2}}; V_{\text{rms}} \equiv \frac{V_m}{\sqrt{2}}$$

Then for a **purely resistive circuit**, we would have:

$$\langle P \rangle = I_{\text{rms}} V_{\text{rms}}$$

You need to know in a particular context if something is talking about peak values or rms values.

RC - LC - RLC - RL series circuits

This analysis applies strictly to a series RLC circuit.

Impedance: We need to define some "resistive-like" quantities

(a) Inductive reactance:  $X_L \equiv \omega L$

(b) Capacitive reactance:  $X_C \equiv \frac{1}{\omega C}$

You can verify that these have units of Ohms.

Let's apply a sinusoidally varying current to the series circuit. At any time across the current is varying throughout the circuit as:

$$I = I_m \sin(\omega t)$$

Impedance for a **series** RLC circuit is then given by:

$$Z = \sqrt{R^2 + (X_L - X_C)^2}$$

An expression which is similar to what might be called Ohm's law for Impedance is:

$$V = IZ$$

The potential drop across the entire circuit will in general not be in phase with the applied current. In fact, it will vary as:

$$V = V_m \sin(\omega t + \delta)$$

For a purely capacitive circuit, the voltage across the capacitor lags behind the current by 90 degrees and the voltage drop across the capacitor is given by  $V_C = IX_C$ . For a RL circuit, the voltage across the inductor leads applied current by 90 degrees and the voltage drop across the inductor is given by  $V_L = IX_L$ . Across a purely resistive circuit, the voltage drop is in phase with the applied current and is given by  $V_R = IR$ .

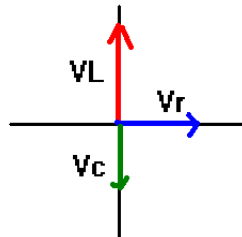

We can write this in terms of two vectors now using the difference between  $V_L$  and  $V_C$ .

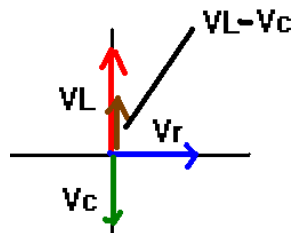

The magnitude of the instantaneous voltage is then given by :

$$|V| = \sqrt{V_R^2 + (V_L - V_C)^2} = I \sqrt{R^2 + (X_L - X_C)^2}$$

The angle between  $V_R$  and this instantaneous voltage is given by:

$$\tan \phi = \frac{V_L - V_C}{V_R} = \frac{X_L - X_C}{R} = \frac{\omega L - \frac{1}{\omega C}}{R}$$

The "power factor" is the cosine of this angle, and the average power radiated by the circuit is related to the power factor by:

$$\langle P \rangle = \langle IV \rangle = I_{\text{rms}} V_{\text{rms}} \cos \phi .$$

Here is another way to get the power factor:

Assuming the current is the same in all parts of the circuit, which is only the situation if we have a series circuit, then:

$$\text{PowerFactor} = \frac{\langle \text{True Power} \rangle}{\langle \text{Apparent Power} \rangle} = \frac{I_{\text{rms}}^2 R}{I_{\text{rms}}^2 Z} = \frac{R}{\sqrt{R^2 + (X_L - X_C)^2}} = \cos \phi$$

Your work today involves analysis of various aspects of the RC and RLC circuit but not actually the power factor. It's worth realizing that the power factor exists, however, and since mostly power is radiated by resistance, it can effectively reduce Joule heating and power losses over DC circuits.

### The RC filter circuits

If the inductance is not present, the impedance is given by:

$$Z = \sqrt{R^2 + \left(\frac{1}{\omega C}\right)^2}$$

voltage output from the capacitor:  $V_C = I X_C \Rightarrow \frac{V_C}{V_{\text{in}}} = \frac{V_{\text{out}}}{V_{\text{in}}} = \frac{\left(\frac{1}{\omega C}\right)}{\sqrt{R^2 + \left(\frac{1}{\omega C}\right)^2}} = \frac{1}{\sqrt{1 + (\omega RC)^2}}$

(2) Voltage output from the resistor:  $\frac{V_R}{V_{\text{in}}} = \frac{IR}{IZ} = \frac{R}{\sqrt{R^2 + \left(\frac{1}{\omega C}\right)^2}} = \frac{\omega RC}{\sqrt{1 + (\omega RC)^2}}$

(1) goes to zero as frequency gets very large. For this reason, it is called a "low pass filter". (2) goes to zero as frequency gets very low. For this reason, it is called a "high pass filter". The amazing thing about this is they both are basically the same circuit ... it just depends what you consider your output to be. In the lab today, you'll measure both. You have to be somewhat careful in practice with how you arrange things since the presence of the ground removes all signals after such a connection.

In the table below, you can obtain limiting behavior by looking at the capacitor: at low frequencies, it is essentially replaced by an open switch while at high frequencies, it is essentially replaced by a closed switch. We will fit the response function  $\mathfrak{R}$  which is also called the circuit gain and designated by  $A_v$ . The phase will not be fit today.

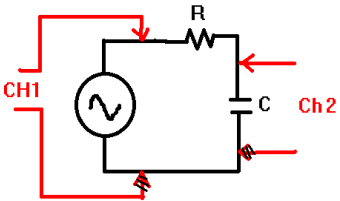
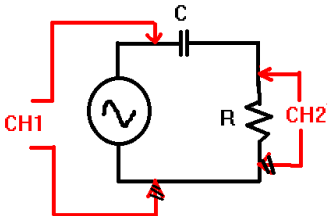
Low Pass Filter connections	High pass filter connections
$\mathfrak{R} \equiv \frac{V_{\text{out}}}{V_{\text{in}}} = \frac{1}{\sqrt{1 + (\omega RC)^2}}$	$\mathfrak{R} \equiv \frac{V_{\text{out}}}{V_{\text{in}}} = \frac{\omega RC}{\sqrt{1 + (\omega RC)^2}}$
Limit: LF: $\mathfrak{R} = 1$	Limit: LF: $\mathfrak{R} = 0$
Limit: HF: $\mathfrak{R} = 0$	Limit: HF: $\mathfrak{R} = 1$
	

For the LP filter circuit, the phase between  $I_r$  and  $V_r$  is given by:

$$\tan \delta = -\frac{X_C}{R} = -\frac{1}{\omega RC} .$$

Today I'll only ask you to measure the phase between an element and the input voltage. You'll see that the phase does indeed shift and as a result of fitting the response function, the phase shift will automatically be provided for the given fit (and it works pretty well). However, the fit can not really distinguish in this analysis between the contribution from R and the contribution from C so therefore the fit is to the product RC. Also, if you look closely enough, you'll see that I fit  $\log_{10}(\tau)$  rather than the time constant itself. You should do the same. Also, the phase reported is no longer the absolute value of the phase which has been improved from previous versions of this lab.

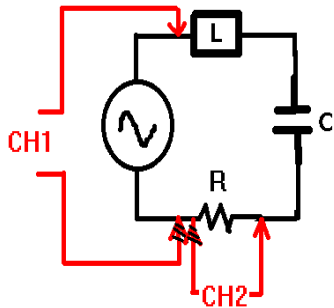

For the RLC circuit, I want you to monitor the voltage drop across the resistor as a function of input frequency and input peak-to-peak voltage and also to take phase measurements. The circuit connections are shown below. The response function is given by:

$$R \equiv \frac{V_{out}}{V_{in}} = \frac{IR}{IZ} = \frac{R}{\sqrt{R^2 + \left(\omega L - \frac{1}{\omega C}\right)^2}} = \frac{1}{\sqrt{1 + \left(\omega \frac{L}{R} - \frac{1}{\omega RC}\right)^2}}$$

$$\Rightarrow R = \frac{1}{\sqrt{1 + \left(\omega \tau_L - \frac{1}{\omega \tau_C}\right)^2}}$$

Resonance will occur in this circuit when the inductive reactance is equal to the capacitive reactance:

$$\text{resonance} \Rightarrow X_L = X_C \Rightarrow \omega_r L = \frac{1}{\omega_r C} \Rightarrow \omega_r = \sqrt{\frac{1}{LC}}$$

In the experiment today, the values of L and C are such that resonance is at about 400Hz. At resonance the response function will reach a maximum value and the power factor will be 1 meaning that the voltage and the current are in phase across the resistor. This circuit is also called the "tank circuit" forms the basis for an enormous number of scientific and real world applications (NMR, Radio, etc.). I want you to observe the response function. The fit will be to the two time constants and also an amplitude owing to additional resistance in the circuit.

**Data analysis:  
For the LP filter:**

$$R \equiv \frac{V_{\text{out}}}{V_{\text{in}}} = \frac{\omega RC}{\sqrt{1+(\omega RC)^2}} \Rightarrow \log(R) = \log(\omega RC) - \frac{1}{2} \log(1+(\omega RC)^2) \approx \log(\omega RC) \text{ as } \omega \rightarrow 0$$

For low frequencies, the response is essentially flat (1 is the predominate term) while at larger frequencies, the log(response) is nearly linear in log(frequency). The phase is given by

$$\tan \delta = -\frac{R}{X_c} = -\omega RC$$

The phase fit will be automatically given as a byproduct of the fit to the frequency response. Place the data into your spreadsheet. Then run the solver. Your target cell is SqrStdDevSD (cell I4) {This is the square root of the standard deviation of the square deviations} which is minimized by changing the time constant,  $\tau$  (cell I2) subject to the constraint that the time constant,  $\tau$  (cell I2)  $\geq 0$ . There is no attempt to fit the phase data. However, do note the behavior of the phase. Also, the phase reported is no longer the absolute value of the phase which has been improved from previous versions of this lab.

**For the HP filter:**

$$R \equiv \frac{V_{\text{out}}}{V_{\text{in}}} = \frac{\omega RC}{\sqrt{1+(\omega RC)^2}} \Rightarrow \log(R) = \log(\omega RC) - \frac{1}{2} \log(1+(\omega RC)^2)$$

$$\tan \delta = \frac{X_c}{R} = \frac{1}{\omega RC}$$

The phase fit will be automatically given as a byproduct of the fit to the frequency response. Place the data into your spreadsheet. Then run the solver. Your target cell is SqrStdDevSD (cell I4) {This is the square root of the standard deviation of the square deviations} which is minimized by changing the time constant,  $\tau$  (cell I2) subject to the constraint that the time constant,  $\tau$  (cell I2)  $\geq 0$ . There is no attempt to fit the phase data. However, do note the behavior of the phase.

The predominate term here is the first: at zero frequency it would diverge, meaning the response function is zero. From there, it increases up to the point at which it levels off at high frequencies and the value there is about given by 1, the log of which is zero. We can fit these outputs to the theoretical response curves and I recommend that you do, but in the logarithmic plane.

### For the RLC resonance circuit:

$$R \equiv \frac{V_{out}}{V_{in}} = \frac{IR}{IZ} = \frac{R}{\sqrt{R^2 + \left(\omega L - \frac{1}{\omega C}\right)^2}} = \frac{1}{\sqrt{1 + \left(\frac{\omega L}{R} - \frac{1}{\omega RC}\right)^2}}$$

For the RLC circuit, I really want you to verify the nature of the response function and also to see how the phase varies up to resonance. In particular, I want you to observe the enormous peak which occurs at resonance in your data. This particular effect is of tremendous importance in many applications. I have not had great success with measurements below about 19 Hz and small frequency adjustments may be required (with the mouse wheel). On JSigGen you may need to increase the %output above 20, however do not increase it above 30% since the signal distortion becomes significantly more pronounced at higher output levels.

Place the data into your spreadsheet. Then run the solver. Your target cell is SqrStdDevSD (cell I8) {This is the square root of the standard deviation of the square deviations} which is minimized by changing the capacitive time constant  $\tau_C$  (cell I2) and the inductive time constant,  $\tau_L$  (cell I4) subject to the constraint that  $\tau_C$  (cell I2)  $\geq 0$  and  $\tau_L$  (cell I4)  $\geq 0$ . Also, you will need to scale the amplitude (cell I6) due to resistance which is not completely accounted for. There is no attempt to fit the phase data. However, do note the behavior of the phase. I hope your results are better than my example. Also, the phase reported is the absolute value of the phase which may be improved in future version of this lab.

### Frequency Analysis Procedure

Start the Tek Analyzer program and also the JSigGen program.

Set the frequency on the ith frequency shown on the frequencies chart. Press the scope "measure" buttons to adjust the <position> knob so that the scan looks somewhat like that shown in figure 1.

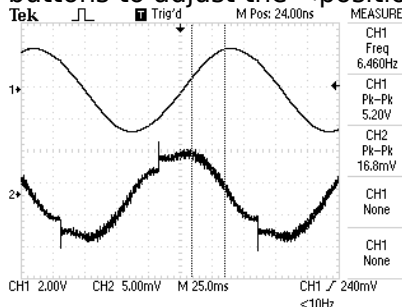

You may need to make additional adjustments with the <Volts/Div> knob for CH2 and also, perhaps for CH1. Additionally, you may need to modify the Horizontal <Sec/Div> knob to insure you obtain a complete enough scan for the frequency measurement to be valid (the program will say invalid measurement if this is not correctly set).

You will also notice that by changing the Trigger <Level> knob, the arrow indicating where the trigger will occur can be modified. I suggest, however, not changing this setting after you set it for your experiment.

Next: press the <Cursor> button: this will allow the two vertical position knobs to control the cursor (vertical lines are the cursor) position. You will want to probably associate knob 2 with channel 2 and knob 1 with channel 1. You should confirm that the Type indicator says Time with source Ch1. By placing the cursors on the curve peaks as shown in figure 2, you are able to make a measurement of the phase. You'll want to do this for each measurement. You will not always, however, need to adjust the curve <position>, <Volts/division> and <sec/div> knobs .... Only about once per decade will these knobs need modification.

Previously, the lower frequencies used signal averaging. It seems unnecessary at this point so I have removed this from the notes. Also the program does not respond to "R" for resetting the average. Press the "space bar" to record the measurement. In all of this, however, make sure the program does not say "Invalid Measurement." If it does, what is needed is to modify the <Sec/Div> knob or occasionally the Ch2 <Volts/Div> knob.

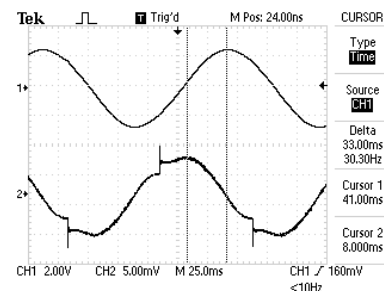

**These notes below are for my reference and ease of setup but you are free to note them**

The initial settings for the TeK are contained in setup 6. Just to make sure about what these settings are, To access them in the easiest way possible, run the program : "Tek Setup 6" (I recommend this strongly). If it is a new scope, you will need to run 9tekset.exe in order to initialize the scope to my communications programs.

Press <Ch1 Menu> button

You should see the following:

Ch1: Coupling DC : BW Limit Off 60 MHz: Volts/Div: Coarse: Probe 1X: Invert Off.

You can change the setting by pressing the button immediately to the right of the menu item on the TeK.

Press <Ch2 Menu> button

Ch2: Coupling DC: BW Limit Off 60 MHz: Volts/Div Coarse: Probe 1X Invert Off

Press the <Trig Menu> button

Trigger: Type Edge : Source CH1 : Slope Rising: Mode Normal: Coupling DC (noise reject if needed)

Press the <display> button (I advise against messing with this unless necessary)

Display: Type Vectors : Persist 1 sec : format yt

Press the <measure> button to return to the normal display, then the <cursors> button to show cursors.

Note that you could have chosen xy in the display format to show ch1 on the x axis and ch2 on the y axis.

The acquisition is for average and 128 scans.

Make sure that the probes are set to 1x and not 10x. They ought to be calibrated at the beginning of the lab each time.

Also upon obtaining a new scope, the easiest way to get it to communicate is to run 9tekset.exe