

Kirchoff's Laws for circuit analysis

Kirchoff's laws work for both ac and dc circuits.

One of Kirchoff's laws you have already used, namely

$$\sum_{\text{closed loop}} V_i = 0$$

This is an expression of energy conservation.

The other of Kirchoff's laws is a consequence of the conservation of charge:

At a junction:

$$\sum_{\text{currents at junction}} I_i = 0$$

With these two laws, it is possible to analyze very complex circuits.

Let me show you how this works for several examples.

I: A single loop circuit

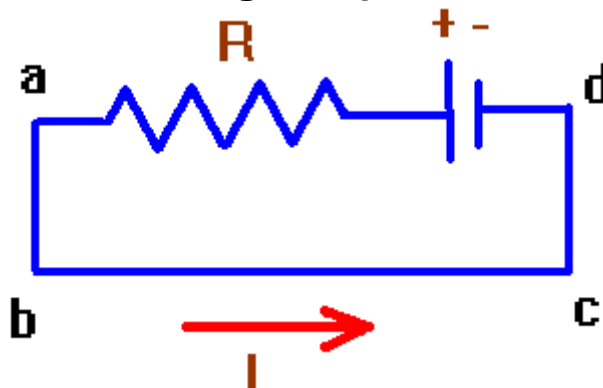

Here, a single loop has no junctions. Trace around the circuit after assigning a direction to the current:

For loop dabcd:

$$\sum_{\text{loop}} V_i = 0 \Rightarrow V - IR = 0 \Rightarrow I = \frac{V}{R}$$

Notice the convention for the signs:

(1) when you go from - to + across a battery, you add +V.

(2) when you go in the direction of the **assigned** current across a resistor, you add -IR. Otherwise, the sign for (1) and (2) is opposite. In the above loop, suppose we chose I in the opposite direction:

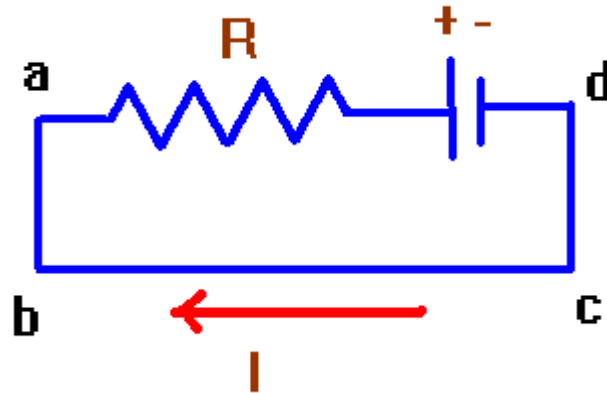

Kirchoff's laws then give for loop dabcd:

$$+V + IR = 0 \Rightarrow I = -\frac{V}{R}$$

Notice that if the current was assigned in the opposite direction to that which it is actually flowing, the result when solving for that current will have a negative sign. This indicates that the direction of the current is actually in the opposite direction to that arbitrarily assigned. What do you do then? You say something like "well, it fooled me" and then carry on. It won't have any other significant impact in an ultimate solution.

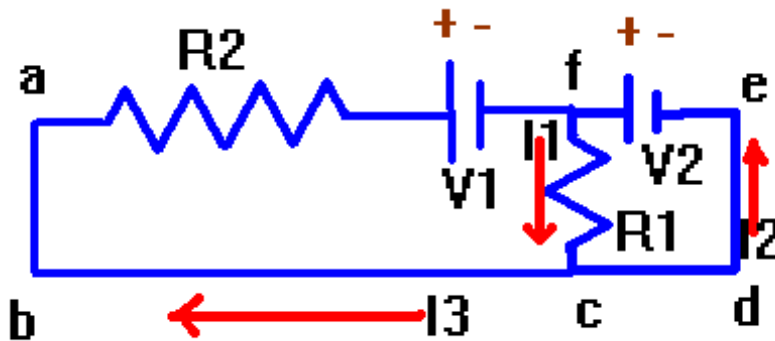
II: A circuit with two loops

In a n -loop circuit, you will need to have $n+1$ current assignments.

You will require n independent loop voltage equations

You will also require $n-1$ junction equations

Note that if a segment of wire contains no elements and joins multiple branches, you should treat this as one big junction in the static situation. You might draw a circle about the wire to do so.

If, after solving, you get negative currents, you say "well, it fooled me" and carry on.

Let's solve this:

(1) since we need two loop equations which are independent, let's pick two from:

(1: abcdefa), (2: abcfa), (3: efcd e)

You can only pick 2 loops, not 3 loops.

I'll here pick #2 and #3:

For loop #2:

$$+I_1 R_1 + V_1 + I_3 R_2 = 0$$

(how did I know I_3 runs through R_2 ?, Why is $I_3 R_2$ positive?)

For loop #3:

$$+V_2 - I_1 R_1 = 0$$

(why did I not use I_2 ?)

Now according to the rules, we have a 2 loop circuit so we need to have 1 junction.

We have junctions at f or at c. Let me choose the junction at c:

$$I_1 - I_2 - I_3 = 0$$

This shows a sign convention for junctions:

Currents going into a junction are called positive.

Currents leaving a junction are called negative.

Notice that you could multiply the above equation by -1 and use a different convention.

So here are our 3 equations which must be simultaneously solved:

$$+I_1 R_1 + V_1 + I_3 R_2 = 0$$

$$+V_2 - I_1 R_1 = 0$$

$$I_1 - I_2 - I_3 = 0$$

On the class website, you will find sites for solving such systems of linear equations.

The solution is:

$$I_1 = \frac{V_2}{R_1} : I_2 = \frac{V_2}{R_1} + \frac{V_1+V_2}{R_2} : I_3 = -\frac{V_1+V_2}{R_2}$$

Let's provide some specific numbers as an example:

Suppose

$$V_1 = 10V; V_2 = 20V; R_1 = 3\Omega : R_2 = 7\Omega$$

Then

$$I_1 = \frac{20}{3} = 6.67A : I_2 = \frac{230}{21} = 10.95A : I_3 = -\frac{30}{7} = -4.29A$$

Notice that I drew I3 in the opposite direction from which it is actually going.
You ought to check your answer in the original equations:

What good is the solution for the currents?

You can now check to obtain the power dissipated in each of the resistors:

$$P = I^2R \Rightarrow P_1 = (6.67)^2 (3) = 133.5W; P_2 = (4.286)^2 (7) = 128.6W$$

The total power dissipated in the circuit is:

$$P = P_1 + P_2 = 133.5W + 128.6W = 261.1W$$

We can also answer the question about what the potential drops across each of the resistor is:

$$V_{R1} = I_1 R_1 = 6.67(3) = 20V$$

$$V_{R2} = I_3 R_2 = 4.286(7) = 30V$$

I've provided a link on the physics home page to several linear equation solvers.

Using the second site with our 3 equations above:

$$+I_1 R_1 + V_1 + I_3 R_2 = 0$$

$$+V_2 - I_1 R_1 = 0$$

$$I_1 - I_2 - I_3 = 0$$

You will obtain the answers (solving for I1, I2 and I3):

$$I_1 = \frac{V_2}{R_1} : I_2 = \frac{V_2}{R_1} + \frac{V_1+V_2}{R_2} : I_3 = -\frac{V_1+V_2}{R_2}$$

You can also put in the numbers from our example above:

$$V_1 = 10V; V_2 = 20V; R_1 = 3\Omega : R_2 = 7\Omega$$

$$I_1 = 20/3 = 6.67A, I_2 = 230/21 = 10.95A, I_3 = -30/7 = -4.29A$$

I recommend adding numerical values as extra equations to be solved here.

I won't be testing you on your ability to use these sites. You will need to be able to write down Kirchoff's laws equations for any circuit which I give you.

III: A 3-loop circuit:

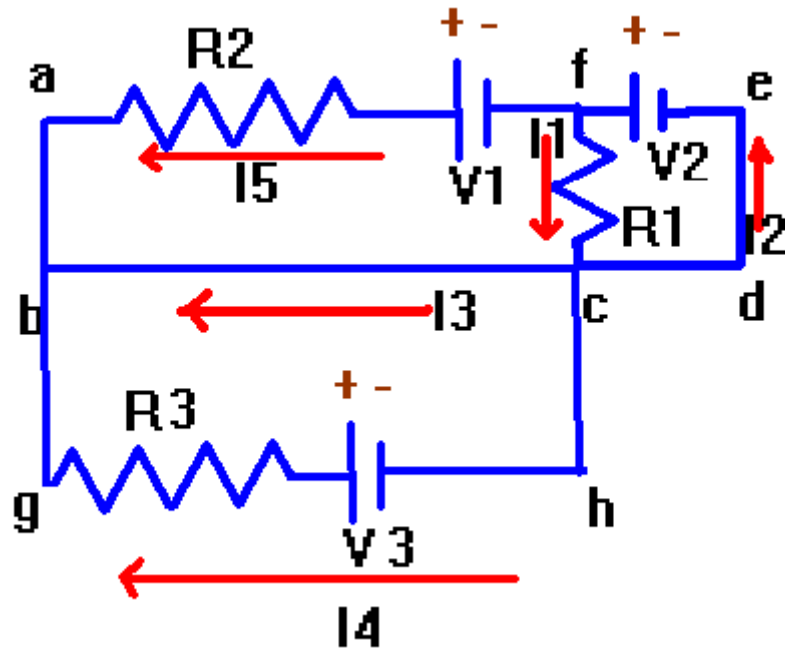

$$(abcfa): +I_1 R_1 + V_1 - I_5 R_2 = 0$$

$$(cdefc): +V_2 - I_1 R_1 = 0$$

$$(ghcbg): I_4 R_3 - V_3 = 0$$

We need also to use 2 junctions: I'm going to choose c b for my junctions:

$$@c: I_1 - I_2 - I_3 - I_4 = 0$$

$$@b: I_4 + I_5 + I_3 = 0$$

Solution:

$$I_2 = - \frac{-R_1 V_1 - R_1 V_2 - R_2 V_2}{R_1 R_2}$$

$$I_3 = - \frac{R_3 V_1 + R_3 V_2 + R_2 V_3}{R_2 R_3}$$

$$I_5 = - \frac{-V_1 - V_2}{R_2}$$

$$I_1 = \frac{V_2}{R_1}$$

$$I_4 = \frac{V_3}{R_3}$$

Let's suppose that we have:
 $R_1=1, R_2=2, R_3=3; V_1=5; V_2=20, V_3=25$
 The solution is:

$$\{I_1, I_2, I_3, I_4, I_5\} = \left\{ 20, \frac{65}{2}, -\left(\frac{125}{6}\right), \frac{25}{3}, \frac{25}{2} \right\}$$

Thus:

$$\begin{aligned} I_1 &= 20A & V_{R1} &= I_1 R_1 = 20V & P_{R1} &= 400W \\ I_2 &= 32.5A & V_{R2} &= I_2 R_2 = 25V & P_{R2} &= 312.5W \\ I_3 &= -20.8A & V_{R3} &= I_3 R_3 = 25V & P_{R3} &= 208.25W \\ I_4 &= 8.33A & & & P_{\text{total}} &= 921W \\ I_5 &= 12.5A & & & & \end{aligned}$$

Notice that now, current I_3 is going opposite to the direction I have drawn.