

Instructions: You have a total of 55 minutes to complete this test.

Answer each question completely showing complete details.

For complete credit you must include correct SI units with numerical answers.

Time Start _____ Time finish _____ pledged _____

$$\text{Constants: } k=8.987 \times 10^9 \frac{\text{Nm}^2}{\text{C}^2}; \epsilon_0=8.854 \times 10^{-12} \frac{\text{C}^2}{\text{Nm}^2}; \mu_0=4\pi \times 10^{-7} \frac{\text{T}}{\text{mA}}$$

[1] Consider a parallel plate capacitor with plates of area A separated by a distance d as shown. You may assume this to be an infinite parallel plate capacitor. The surface charge density at $x=0$ is $+\sigma$ and the surface charge density at $x=d$ is $-\sigma$ as shown.

(a) Sketch the vector electric field for the following regions: ($x < 0$), ($0 < x < d$) and ($x > d$) on the diagram.

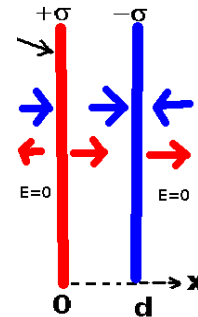
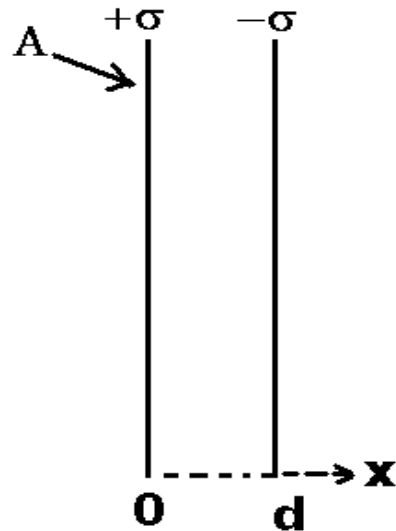

(b) Showing complete details and assumptions (using sketches as needed), calculate the vector electric field inside the capacitor. You must show full details here for credit.

Your answer involves σ and ϵ_0 .

Choose a cylinder with ends of area A' . Orient the cylinder so that the ends are parallel to the planes. Let the cylinder cut through the plane at zero but not at d . On the end between the plates, E is parallel to the end and uniform. On the LSA, E is perpendicular to A . On the end outside the capacitor, $E=0$. Thus:

$$\Phi_E = EA' = \frac{Q_{\text{enc}}}{\epsilon_0} = \frac{\sigma A'}{\epsilon_0} \Rightarrow E = \frac{\sigma}{\epsilon_0} \Rightarrow \vec{E} = \frac{\sigma}{\epsilon_0} \hat{x}$$

(c) The capacitance of the parallel plate capacitor is given by $C = \epsilon_0 \frac{A}{d}$. Suppose the separation of the plates is $d=0.1$ m and the area of the plates is $A=1$ m². If the potential difference between the plates is $V=10$ V, find the energy density together with correct SI units inside the capacitor.

$$|V| = |Ed| \Rightarrow |E| = \frac{|V|}{d} = \frac{10 \text{ V}}{0.1 \text{ m}} = 100 \frac{\text{V}}{\text{m}}$$

$$u = \frac{1}{2} \epsilon_0 E^2 = 8.85 \times 10^{-12} \times 10^4 = 4.425 \times 10^{-8} \frac{\text{J}}{\text{m}^3}$$

(e) Suppose in a region of space, the potential is given by $V = 5x$. Find the **vector** electric field in this region.

$$\vec{E} = -\frac{\Delta V}{\Delta x} \hat{x} = -5 \hat{x}$$

Note that the electric field is the negative slope of the potential (with a vector).

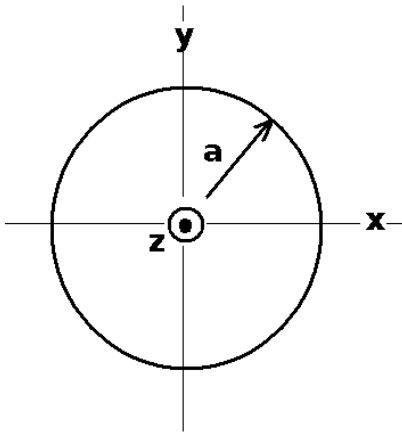

[2] A wire of radius a carries a uniform current density given by $\vec{J} = |\vec{J}|\hat{z}$ which is directed out of the page as shown. The wire carries a total current I .

(a) Which direction does the magnetic field circulate around the wire? (circle the correct answer below).

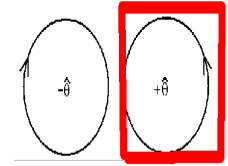
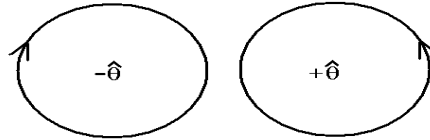

(b) Calculate the magnitude of the current density in terms of I and a .
The current is uniformly spread over the cross section of the wire so the current density is given by: $|\vec{J}| = \frac{I}{A} = \frac{I}{\pi a^2}$

(c) Showing complete details, including sketches as necessary, calculate the vector magnetic field inside the wire in terms of I , a and the radius vector r .
Choose a circular path centered on the wire of radius $s < a$. On that path, B is uniform in magnitude and direction (it circulates parallel to the path) . Then from Ampere's law we have:

$$\sum_{\Delta S_i} \vec{B}_i \cdot \Delta \vec{S}_i = \mu_0 I_c \Rightarrow B(2\pi r) = \mu_0 \frac{I}{\pi a^2} \pi r^2 = \mu_0 \frac{r^2}{a^2} \Rightarrow \vec{B} = \frac{\mu_0}{2\pi a^2} r \hat{\phi}$$

(d) Showing complete details, including sketches as necessary, calculate the vector magnetic field outside the wire in terms of I , and the radius vector r .
Choose a circular path centered on the wire of radius $s > a$. On that path, B is uniform in magnitude and direction (it circulates parallel to the path) . Here, however, all the current is enclosed by the path chosen. Then from Ampere's law we have:

$$\sum_{\Delta S_i} \vec{B}_i \cdot \Delta \vec{S}_i = \mu_0 I_c \Rightarrow B(2\pi r) = \mu_0 I \Rightarrow \vec{B} = \frac{\mu_0 I}{2\pi r} \hat{\phi}$$

(e) Suppose $I = 1$ A and $a = 0.1$ m. Find the magnitude of the magnetic field at the surface of the wire with correct SI units.

at the surface of the wire, $|\vec{B}| = \frac{\mu_0 I}{2\pi a} = \frac{4\pi \times 10^{-7} \times 1}{2\pi \times 0.1} = 2.0 \times 10^{-6} \text{ T}$

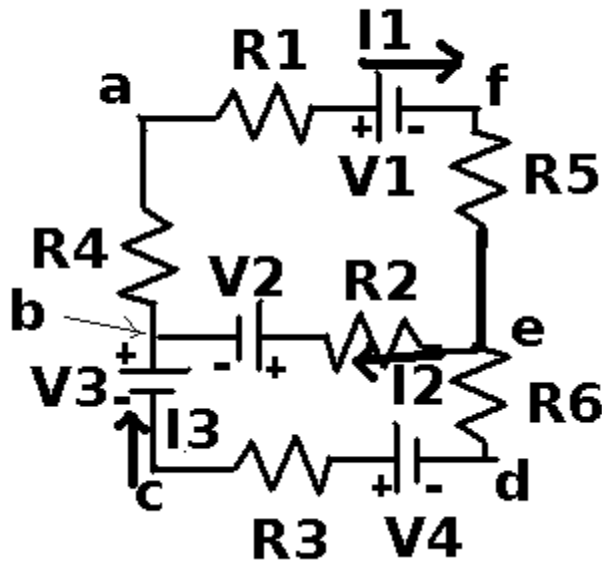

[3] Consider the circuit shown to the left.

(a) Provide the Kirchoff's laws equations for the following loops and junction:

(afeba):

$$-I_1 R_1 - V_1 - I_1 R_5 - I_2 R_2 - V_2 - I_1 R_4 = 0$$

(bedcb):

$$+V_2 + I_2 R_2 - I_3 R_6 + V_4 - I_3 R_3 + V_3 = 0$$

@e: $I_1 - I_2 - I_3 = 0$

(b) Suppose for the following values: $(R_1, R_2, R_3, R_4, R_5, R_6) = (1, 2, 3, 4, 5, 6)\Omega$

and for the following voltages: $(V_1, V_2, V_3, V_4) = (1, 2, 3, 4)V$

the following currents result: $I_1 = -.118A$, $I_2 = -.914A$, $I_3 = .797A$.

Calculate the total power dissipated in the circuit (with correct SI units).

$$P = (R_1 + R_5 + R_4)I_1^2 + R_2 I_2^2 + (R_3 + R_6)I_3^2 = (1 + 5 + 4)(.118)^2 + 2(.914)^2 + (3 + 6)(.797)^2$$

$$P = 0.14 + 1.67 + 5.71 = 7.53W$$

(c) What is the interpretation for the value of the current I_2 ?

The current actually flows in the opposite direction to the assumed direction.

[4] Note: be sure to include correct SI units with your answers below.

(a) Graphite has a resistivity of $7.84 \times 10^{-6} \Omega \cdot \text{m}$. What is the resistance of a 1 m long graphite rod of cross sectional area $A = 0.01 \text{m}^2$ in the shape of a cylinder across the ends?

$$R = \rho \frac{L}{A} = (7.84 \times 10^{-6}) \times \frac{1}{0.01} = 7.84 \times 10^{-4} \Omega$$

(b) Graphite has a dielectric constant of about 15. What is the capacitance of a rectangular piece of graphite of area $A = 0.1 \text{m}^2$ and thickness $d = 0.01 \text{m}$?

Note from problem 1(c) the capacitance of a parallel plate capacitor.

$$C = \kappa C_{\text{geo}} = 15 \times \epsilon_0 \frac{A}{d} = 15 \times 8.85 \times 10^{-12} \times \frac{.1}{.01} = 1.32 \times 10^{-9} \text{f}$$

(c) If a 300Ω resistor is placed in series with a 600Ω resistor, what is the equivalent resistance?

$$R_1 \text{ series } R_2 \Rightarrow R_{\text{eq}} = R_1 + R_2 = 300 + 600 = 900 \Omega$$

(d) If a 300Ω resistor is placed in parallel with a 600Ω resistor, what is the equivalent resistance?

$$R_1 \text{ parallel } R_2 \Rightarrow \frac{1}{R_{\text{eq}}} = \frac{1}{R_1} + \frac{1}{R_2} = \frac{1}{300} + \frac{1}{600} = \frac{2+1}{600} = \frac{3}{600} \Rightarrow R_{\text{eq}} = \frac{600}{3} = 200 \Omega$$

(e) If a $4 \mu\text{f}$ capacitor is placed in series with a $6 \mu\text{f}$ capacitor, what is the equivalent capacitance?

$$C_1 \text{ series } C_2 \Rightarrow \frac{1}{C_{\text{eq}}} = \frac{1}{C_1} + \frac{1}{C_2} = \frac{1}{4} + \frac{1}{6} = \frac{3+2}{12} = \frac{5}{12} \Rightarrow C_{\text{eq}} = \frac{12}{5} = 2.4 \mu\text{f} = 2.4 \times 10^{-6} \text{f}$$

(f) If a $4 \mu\text{f}$ capacitor is placed in parallel with a $6 \mu\text{f}$ capacitor, what is the equivalent capacitance?

$$C_1 \text{ parallel } C_2 \Rightarrow C_{\text{eq}} = C_1 + C_2 = 6 + 4 = 10 \mu\text{f} = 1.0 \times 10^{-5} \text{f}$$