

Instructions: You have a total of 55 minutes to complete this test.

Answer each of the following questions completely.

Time Start _____ Time finish _____ Pledged _____

You must supply all details that led to your answer.

You must provide correct SI units where required.

Do not discuss any aspect of this test with anyone until I return the test.

Although you may use additional sheets of paper which should be turned in with your test, please write (neatly) your answers on the pages where the problems are presented.

Constants: $e^- = -1.602 \times 10^{-19} \text{C}$, $k = 8.99 \times 10^9 \frac{\text{Nm}^2}{\text{C}^2}$, $\epsilon_0 = \frac{1}{4\pi k} = 8.85 \times 10^{-12} \frac{\text{C}^2}{\text{Nm}^2}$

(1) A material having a dielectric constant $\kappa = 3.5$ is inserted completely inside a capacitor. The capacitance is measured to be $10 \mu\text{f}$ with the material inside.

(a) What is the geometrical capacitance of the system together with correct SI units?

(b) Suppose that C_{geo} was equal to $25 \mu\text{f}$. If two of these empty capacitors are connected in parallel, calculate the equivalent capacitance.

(c) Suppose that C_{geo} was equal to $25 \mu\text{f}$. If two of these empty capacitors are connected in parallel. Calculate the equivalent capacitance.

A rod had a cross sectional area $A = 3 \times 10^{-2} \text{m}^2$ and it is 3.0 m long. The material which the rod is made of has a resistivity given by $\rho_R = 2 \times 10^{-7} \Omega\text{m}$.

(e) Calculate the resistance of the rod.

(f) Suppose the resistance of the rod was 1.3Ω . If two of these rods are connected in parallel, calculate the equivalent resistance.

(g) Suppose the resistance of the rod was 1.3Ω . If two of these rods are connected in series, calculate the equivalent resistance.

Note: on problem 2 you must show complete details, using sketches. Simply putting down answers will not obtain much credit here.

(2) A parallel plate capacitor has plates of area A and separation d . On the plate located at the origin, a surface charge density $+\sigma$ exists while on the plate located at d a surface charge density $-\sigma$ exists. Answer the following assuming that this can be regarded as an ideal capacitor.

(a) Starting from Gauss's Law, show (showing complete details) how to calculate the vector electric field within the capacitor in terms of σ, ϵ_0 and \hat{x} .

(b) Calculate the **magnitude** of the potential difference between the two plates in terms of σ, ϵ_0 and d .

(c) Calculate the capacitance of the capacitor in terms of ϵ_0, A , and d .

(d) Calculate the total energy stored on the capacitor in terms of C and V .

(e) Calculate the energy density in terms of ϵ_0 and E .

(f) Suppose the capacitor plates have a potential difference of 100V and the plates are separated by $d=0.1$ m. Provide a numerical answer for the energy density together with correct SI units.

(e) Now suppose that in some region of space the electric potential is given by:
 $V = c + ax^2$ where a and c are constants. What is the vector electric field in this region of space?

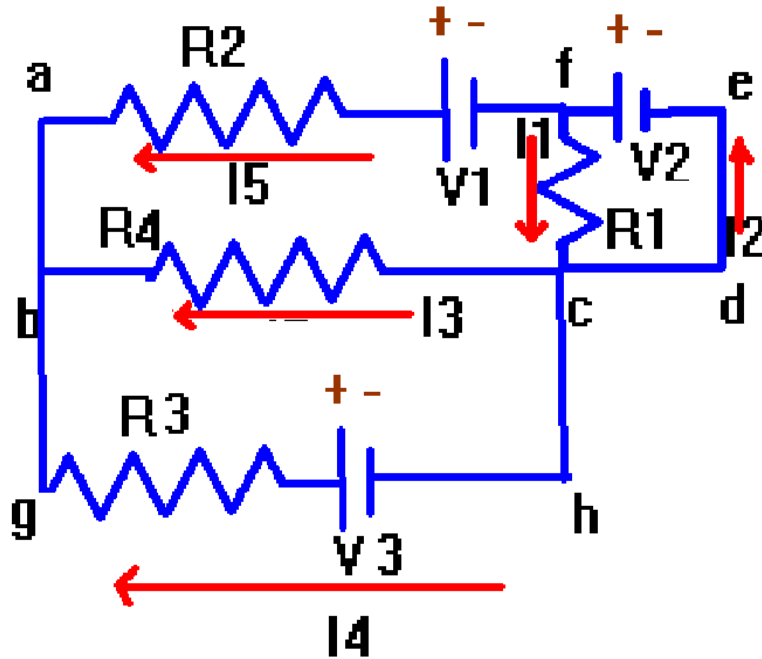

[3] Consider the circuit shown above.

(a) Write down Kirchoff's loop equations for the following three loops:

(abcfa): _____

(bghcb): _____

(fcdef): _____

(b) Write down Kirchoff's junction equations for the following two junctions:

@c: _____

@f: _____

Suppose that you have the following values for voltages and resistances:

$$V_1=10V: V_2=20V: V_3=30V: R_1=1\Omega: R_2=2\Omega: R_3=3\Omega: R_4=4\Omega.$$

If the currents are: $I_1=2A: I_2=3.4A: I_3=5.8A: I_4=-2.31: I_5=3.46A$, then:

(c) Calculate the total power dissipated in the circuit together with correct SI units.

(d) What is the interpretation of the current provided for I_4 ?

4. A wire in the form of a long (infinite) solid cylinder of radius a has a current I uniformly spread across its cross sectional area. Surrounding the wire is a long (infinite) hollow cylinder of radius c ($c > a$) and it has a return current $-I$.

(a) Calculate the magnitude of the current density inside the inner wire assuming the current flows along the axis.

Your answer will involve I , and a .

(b) Calculate the magnetic field inside the wire at a distance s ($s < a$). Your answer will involve J , and s .

(c) Calculate the magnetic field between the wire and the hollow cylinder at a distance s ($a < s < c$). Your answer will involve I and s .

(d) Calculate the magnetic field outside the cylinder at a distance s ($s > c$).

(e) If $I = 1$ A and $a = .01$ m, provide a numerical value for B at the surface of the wire.