

(1) A mass M_1 is on a frictionless table and is connected to a mass M_2 by a string which is hanging over the side of the table. Find the tension and the acceleration.

(2) Solve problem 1 where there is a frictional force f present.

(3) Solve for the tension and acceleration of Atwood's machine.

(4) Suppose a block of wood of mass m is kicked along the floor with an initial velocity v . The block has a coefficient of kinetic friction of μ between the floor and the block. How far will the block slide till it stops. If the block has an initial velocity $v=5$ m/s and $\mu=0.3$, provide a numerical answer together with correct units.

(5) A block of wood (m_1) of mass m is connected to another block of wood (m_2) of the same mass by a string. Both masses are lying on a table and there is a coefficient of friction between the masses and the table of μ . The string is initially stretched. The system is set in motion with an initial velocity v_0 . How far does the system move until it stops?

(1) A mass M_1 is on a frictionless table and is connected to a mass M_2 by a string which is hanging over the side of the table. Find the tension and the acceleration.

Solution: Unbend the problem: **Use the free body diagrams as shown in class.**

$$\begin{aligned} \text{fb1: } y: N - m_1g &= 0 & \text{fb2: } m_2g - T &= m_2a \\ x: T &= m_1a & & \text{no other equation} \end{aligned}$$

To solve:

$$N = m_1g \text{ (no further use of this in this problem)}$$

$$\text{add } T = m_1a \text{ and } m_2g - T = m_2a:$$

$$\begin{aligned} &T = m_1a \\ + &\frac{m_2g - T = m_2a}{m_2g = (m_1 + m_2)a} \end{aligned}$$

$$m_2g = (m_1 + m_2)a \Rightarrow a = \frac{m_2}{m_1 + m_2}g \Rightarrow T = \frac{m_1m_2}{m_1 + m_2}g$$

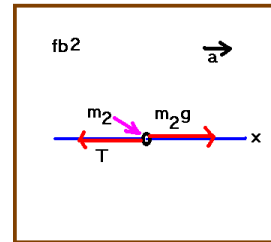
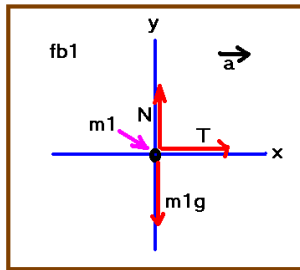
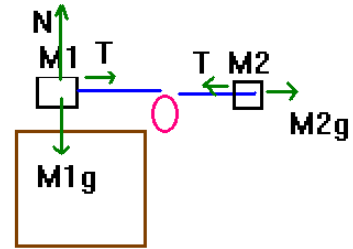
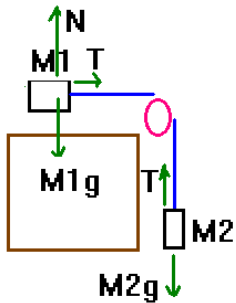

(2) Solve problem 1 where there is a frictional force f present.

Solution: Unbend the problem: **Use the free body diagrams as shown in class.**

$$\begin{aligned} \text{fb1: } & y: N - m_1g = 0 \\ & x: T - f = m_1a \\ \text{fb2: } & m_2g - T = m_2a \\ & \text{no other equation} \end{aligned} \quad f = \mu N$$

$$N = m_1g \Rightarrow f = \mu m_1g \Rightarrow T - \mu m_1g = m_1a$$

add $T - \mu m_1g = m_1a$ and $m_2g - T = m_2a$:

$$\begin{aligned} & T - \mu m_1g = m_1a \\ + & m_2g - T = m_2a \\ \hline & (m_2 - \mu m_1)g = (m_1 + m_2)a \end{aligned}$$

$$(m_2 - \mu m_1)g = (m_1 + m_2)a \Rightarrow a = \frac{(m_2 - \mu m_1)}{m_1 + m_2}g$$

$$\Rightarrow T = \mu m_1g + m_1a = m_1 \left(\frac{(\mu m_1 + m_2) + (m_2 - \mu m_1)}{m_1 + m_2} \right)g = (\mu + 1)m_1 \left(\frac{m_2}{m_1 + m_2} \right)g$$

Notice that if $\mu=0$ (no friction) we have the previous problem.

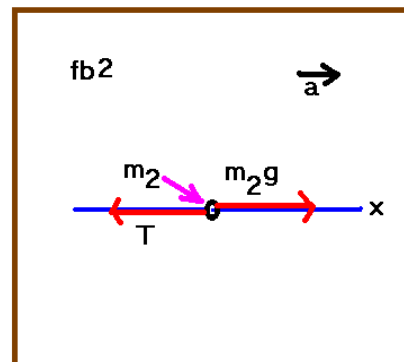
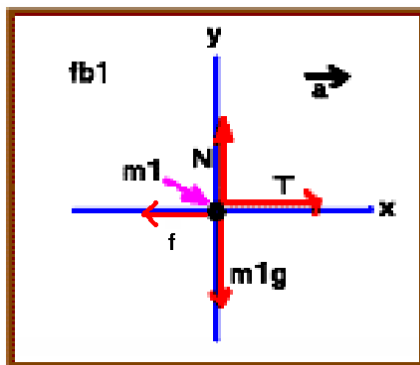
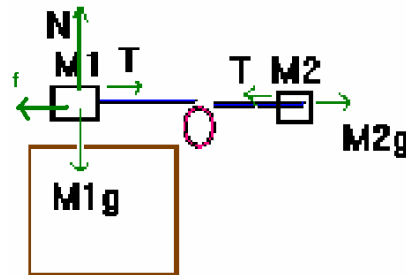
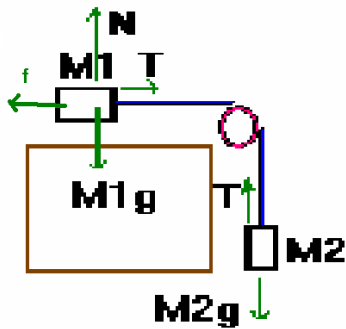

(3) Solve for the tension and acceleration of Atwood's machine.

Solution: An animated gif exists under the lab homepage which shows the steps needed to solve this problem (see lab 3).

(4) Suppose a block of wood of mass m is kicked along the floor with an initial velocity v . The block has a coefficient of kinetic friction of μ between the floor and the block. How far will the block slide till it stops. If the block has an initial velocity $v=5$ m/s and $\mu=0.3$, provide a numerical answer together with correct units.

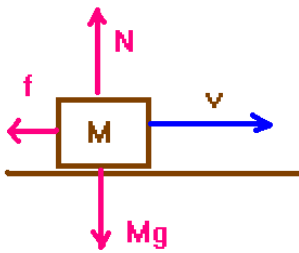

Here is a picture of the problem. The initial problem is that only external force which is not balanced here is the frictional force. It causes an acceleration in the opposite direction to the velocity. You are going to want to reverse the problem so that the acceleration is in the positive direction. The free body diagram for this is shown below. **Remember: the acceleration is always in the direction of the net external force!**

I have obeyed my rule here in that I have directed the acceleration in the $+x$ direction which means that the initial velocity thus is in the $-x$ direction.

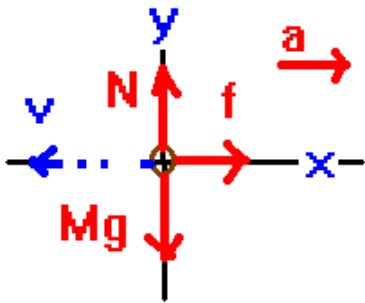

Newton's laws give:

$$\sum \vec{F} = m\vec{a} \Rightarrow \begin{matrix} N - Mg = 0 \\ f = Ma \end{matrix}. \text{ Of course, we}$$

have the constitutive equation:

$$f = \mu N \Rightarrow f = \mu Mg.$$

With the frictional force given above, we are now ready to solve for the acceleration:

$$\mu Mg = Ma \Rightarrow a = \mu g. \text{ How far does it go?}$$

This is given by one of the equations of

motion:

$$0 = v_i^2 + 2a(\Delta x) \Rightarrow \Delta x = -\frac{v_i^2}{2\mu g}. \text{ The - sign is appropriate here. Now,}$$

$$\text{putting numbers into this, we find } \Delta x = -\frac{25}{2(0.3)(9.8)} = 4.25\text{m}.$$

(5) A block of wood (m_1) of mass m is connected to another block of wood (m_2) of the same mass by a string. Both masses are lying on a table and there is a coefficient of friction between the masses and the table of μ . The string is initially stretched. The system is set in motion with an initial velocity v_0 . How far does the system move until it stops?

A diagram for the system looks like the figure shown below. The acceleration is in the $-x$ direction which is likely to cause problems. One easy way for me to fix this situation is to flip the system.

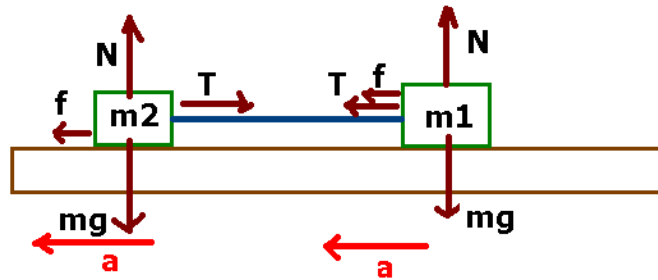

Flipping this image by the horizontal produces the following image:

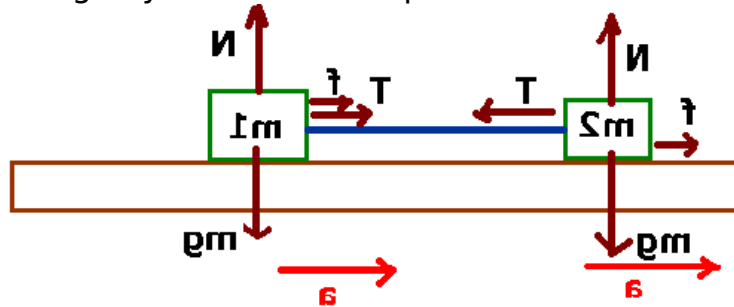

I can now write Newton's laws for the system although it's useful to refer to the first image also. The following equations result:

$$\begin{aligned} f_2 - T &= m_2 a & T + f_1 &= m_1 a \\ N_2 - m_2 g &= 0 & N_1 - m_1 g &= 0 \\ f_2 = \mu N_2 &= \mu m_2 g & f_1 = \mu N_1 &= \mu m_1 g \end{aligned}$$

We can simplify using the fact that all the masses are the same. The result is:

$$\begin{aligned} \mu mg - T &= ma \\ T + \mu mg &= ma \end{aligned}$$

The tension is eliminated by adding the two equations:

$$2\mu mg = 2ma \Rightarrow a = \mu g; T = ma - \mu mg = 0$$

We can now find out how far it travels until it stops:

$$v^2 = v_0^2 + 2a(\Delta x) \Rightarrow \Delta x = \frac{-v_0^2}{2a} = -\frac{v_0^2}{2\mu g}$$

If you would like to put numbers on this, suppose the coefficient of friction is 0.05 and the initial velocity is 1 m/s (in the $-x$ direction). The system will travel a distance of

$$\Delta x = -\frac{1}{2(0.05)9.8} = -1.02\text{m}$$

until it stops. The fact that the tension is zero says that the string really does not play any significant role in this problem and I like the idea of a stretched string under zero tension as an example of the approximations we sometimes use in these problems.